

P141XL

Pressurised-water temperature control unit up to 140 °C

- Control system RT100 or RT200
- Innovative pressure control
- Patented low-scale cooling system "SK"
- Pump with high pumping capacity: 200 l/min
- Modular configuration



Heat transfer medium	Outlet temperature	Heating capacity at 400V	Cooling capacity		Pump capacity/Type		
Water	140 °C	20 / 40 / 60 kW	130 °C	115 kW	SG85	200 l/min	3.5 kW



Regloplas AG

Flurhofstrasse 158 • 9006 St.Gallen • Schweiz • T +41 71 2825800
 F +41 71 2825840 • info@regloplas.com • www.regloplas.com

Technical data		
Outlet temperature		
max.	°C	140
Heat transfer medium		Water
Filling quantity	l	10
Expansion volume	l	5.0
Heating capacity at 400V	kW	20 / 40 / 60
Cooling capacity	kW	115
Cooler		SK
at outlet temperature	°C	130
at cooling water temperature	°C	20
Pump capacity/Type		SG85
Flow rate max.	l/min	200
Power consumption	kW	3.5
Pressure max.	bar	5.3
Control system		RT100 / RT200
Measuring mode (Standard)		Pt100
Operating voltage	V/Hz	200-600/50-60
Connections		
Outlet/Inlet		G1 1/2"IG
Cooling water mains		G3/4"
Degree of protection		IP54
Dimensions W/H/D	mm	432/1350/1554
Weight	kg	265
Color	RAL	9006/7016
Ambient temperature		
max.	°C	40
Noise level	db (A)	< 70



Regloplas AG

Flurhofstrasse 158 • 9006 St.Gallen • Schweiz • T +41 71 2825800
F +41 71 2825840 • info@regloplas.com • www.regloplas.com

Standard equipment

- Solid-state relay (SSR) instead of heating contactor
- Manual shut-off valve in the inlet and outlet
- Water circuit of non-rusting materials
- Automatic water refill
- Filter in the main circuit
- Filter in the cooling water circuit
- Patented low-scale cooling system "SK"
- Pressure gauge outlet
- Pressure gauge for system pressure
- Unit in IP54 protection degree

Options

- Electronic flow measurement



Regloplas AG

Flurhofstrasse 158 • 9006 St.Gallen • Schweiz • T +41 71 2825800
F +41 71 2825840 • info@regloplas.com • www.regloplas.com

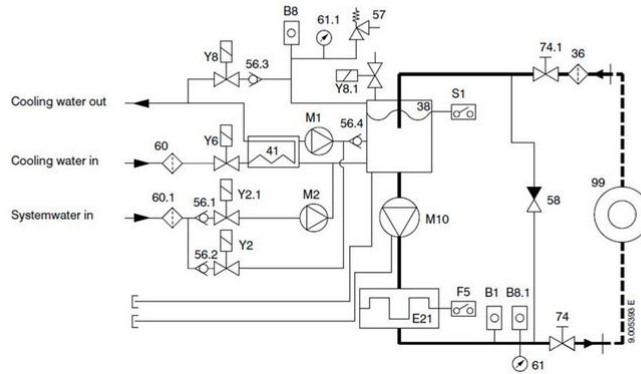

36 Filter main circuit	60 Filter cooling circuit	E21 Heater	Y2 Solenoid valve, automatic water refill
38 Tank	61 Pressure gauge	F5 Safety thermostat	Y2.1 Solenoid valve, water refill (pressure control)
41 Cooler	61.1 Pressure gauge	M1 Cooling pump (cooler "SK")	Y6 Solenoid valve, cooling
56.1 One-way check valve	74 Hand valve	M2 Filling pump	Y8 Solenoid valve, pressure release
56.2 One-way check valve	74.1 Hand valve	M10 Pump	Y8.1 Solenoid valve, additional pressure release
56.3 One-way check valve	99 Consumer	S1 Level control	
56.4 One-way check valve	B1 Temperature sensor internal		
58 Bypass	B8 System pressure sensor		
57 Safety valve	B8.1 Outlet pressure sensor		

36 Filter Hauptkreislauf	60 Filter Kühlkreislauf	E21 Heizung	Y2 Magnetventil automatische Wassernachfüllung
38 Behälter	61 Manometer	F5 Sicherheitsthermostat	Y2.1 Magnetventil Wassernachfüllung (Druckregelung)
41 Kühler	61.1 Manometer	M1 Kühlepumpe (Kühler "SK")	Y6 Magnetventil Kühlung
56.1 Rückschlagventil	74 Handventil	M2 Füllpumpe	Y8 Magnetventil Druckentlastung
56.2 Rückschlagventil	74.1 Handventil	M10 Pumpe	Y8.1 Magnetventil Zusatzdruckentlastung
56.3 Rückschlagventil	99 Verbraucher	S1 Niveauekontrolle	
56.4 Rückschlagventil	B1 Temperaturfühler intern		
58 Bypass	B8 Drucksensor Systemdruck		
57 Sicherheitsventil	B8.1 Drucksensor Vorlaufdruck		

Graph (pump capacity)

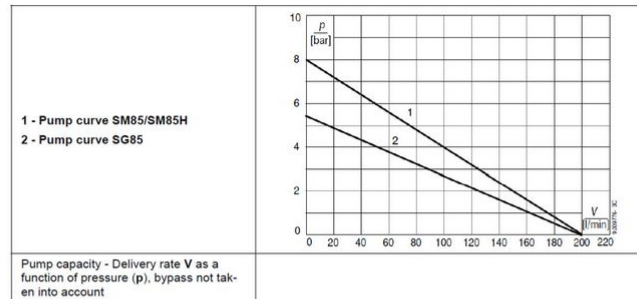

Diagramm (Pumpenleistung)

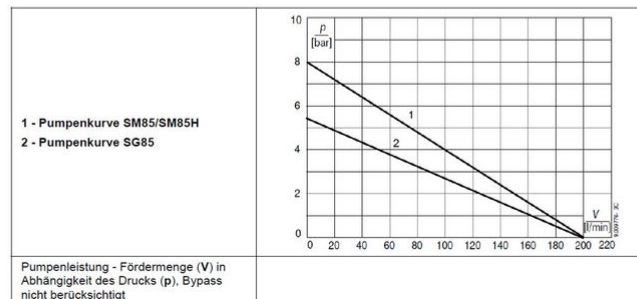

Regloplas AG

Flurhofstrasse 158 • 9006 St.Gallen • Schweiz • T +41 71 2825800
F +41 71 2825840 • info@regloplas.com • www.regloplas.com